

SPOOL VALVE HYDRAULIC MOTORS

CONTENTS

	Page
● Hydraulic Motors Series MM	4
● Hydraulic Motors Series MP	13
● Hydraulic Motors Series MR	32
● Hydraulic Motors Series MR...T (tacho).....	43
● Hydraulic Motors Series MRNA	44
● Hydraulic Motors Series MRFL	45
● Hydraulic Motors with Dual Shaft Series MRB	46
● Hydraulic Motors Series PL	49
● Hydraulic Motors Series RL	54
● Hydraulic Motors Series PK	58
● Hydraulic Motors Series RK	62
● Hydraulic Motors Series RW	66
● Hydraulic Motors Series MH	77
● Hydraulic Motors Series HW	84
● Motor Special Features.....	98
● Motors with Speed Sensor.....	99
● Application Calculations	101

SPOOL VALVE HYDRAULIC MOTORS

GENERAL INFORMATION:

Orbit motors convert hydraulic energy (pressure, oil flow) into mechanical energy (torque, speed). Hydraulic orbit motors operate on the principle of an internal gear (rotor) rotating within a fixed external gear (stator). The internal gear transmits the torque generated by the application of pressure from hydraulic oil fed into motor which is then delivered via the motor's output shaft. Orbit motors have high starting torque and constant output torque at wide speed range.

DISTRIBUTOR VALVE

MM, MP, MR, MH, PL, RL, PK, RK, RW, HW series motors have spool valve: the distributor valve has been integrated with the output shaft. The cardan shaft rotates distributor valve and transfers mechanical energy from gerotor set to output shaft. The valve has hydrodynamic bearings and has infinite life when load ratings are not exceeded.

GEARWHEEL SET

There are two forms of gearwheel set:

- Gerotor set have plain teeth. These types motors are suitable for long operating periods at moderate pressures or short operating periods at high pressures. MM, MP, PL and PK series motors have gerotor set.

- Roll-gerotor set have teeth fitted with rollers. The rollers reduce local stress and the tangential reaction forces on the rotor reducing friction to a minimum. This gives long operating life and better efficiency even at continuous high pressures. Roll-gerotor sets are recommended for operation with thin oil and for applications with continually reversing loads. MR, RL, RK, MH, RW and HW series motors have roll-gerotor set.

FEATURES:

Standard Motor The standard motor mounting flange is located as close to the output shaft as possible. This type of mounting supports the motor close to the shaft load. This mounting flange is also compatible with many standard gear boxes.

Wheel Motor W mounting flange makes the motors possible to fit a wheel hub or a winch drum so that the radial load acts closer to motor bearings. This gives the best utilization of the bearing capacity and is a very compact solution.

Needle Bearing MPN and MRN have an output shaft supported in needle bearing. These types motors are suitable for operating conditions such as frequent start and stops, vibration on the shaft, high static and dynamic radial loads in short operating terms.

Low Leakage LL Series hydraulic motors are designed to operate at the whole standard range of working conditions (pressure drop and frequency of rotation), but with considerable decreased volumetric losses in the drain ports. These motors are suitable for hydraulic systems with series-connected motors with demands for low leakage.

Low Speed Valve LSV feature optimizes the motor for low-speed performance. Motors with this valving provide very speed while maintaining high torque. They are designed to run continuously at low speed (up to 200 min⁻¹) at normal pressure drop and reduced flow. Optimal run is guaranteed at frequency of rotation from 20 to 50 min⁻¹. Motors with this valving have an increased starting pressure and are not recommended for using at pressure drop less than 40 bar.

Free Running FR motors are with increased clearance at all friction parts, allowing the shaft to rotate more freely with less mechanical drag. The increased clearance also improves lubrication of the wear surfaces of gear set and friction parts. Additional advantages of "FR" version are prolonging of the life of the hydraulic motors at high speeds, as well as the possibility to use them in systems with wide variation of the loading. FR Series motors are designed to operate with high speed /over than 300 min⁻¹ and low pressure drop. Volumetric efficiency may be reduced slightly.

High Pressure Shaft Seal The high pressure shaft seals allow the motors to withstand high case pressures at high speeds without external drain line.

Motors with Speed Sensor Motors are available with integrated inductive speed sensor. The output signal is a standardized voltage signal that can be used to control the speed of a motor. The torque and the radial load of the motor are not affected by the installation of speed sensor.

HYDRAULIC MOTORS MM



APPLICATION

- » Conveyors
- » Textile machines
- » Mining machinery
- » Machine tools
- » Ventilators
- » Construction plant equipment and access platforms etc.

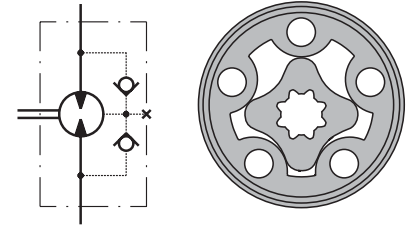

CONTENTS

Specification data	5
Function diagrams	6÷8
Dimensions and mounting ...	9÷10
Shaft extensions	11
Permissible shaft loads	11
Order code	12

OPTIONS

- » Model- Spool valve, gerotor
- » With or without flange
- » Side and rear ports
- » Series with pressure valve(s)
- » Shafts- straight and splined
- » Metric and BSPP ports
- » Speed sensing;
- » Other special features

GENERAL

Max. Displacement, cm ³ /rev [in ³ /rev]	50 [3.05]
Max. Speed, [RPM]	2440
Max. Torque, daNm [in-lb]	cont.: 4,5 [398] int.: 5,8 [513]
Max. Output, kW [HP]	3,2 [4,3]
Max. Pressure Drop, bar [PSI]	cont.: 105 [1500] int.: 140 [2030]
Max. Oil Flow, lpm [GPM]	25 [6.6]
Min. Speed, [RPM]	20
Pressure fluid	Mineral based- HLP(DIN 51524) or HM(ISO 6743/4)
Temperature range, °C [°F]	-40÷140 [-40÷284]
Optimal Viscosity range, mm ² /s [SUS]	20÷75 [98÷347]
Filtration	ISO code 20/16 (Min. recommended fluid filtration of 25 micron)

MMP Series with Integrated Internal Crossover Relief Valve
A → B, Δp=100 or 50 bar [1450 or 725 PSI]

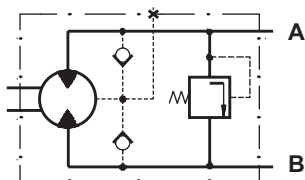

MMP Series with Integrated Internal Crossover Relief Valve
B → A, Δp=100 or 50 bar [1450 or 725 PSI]

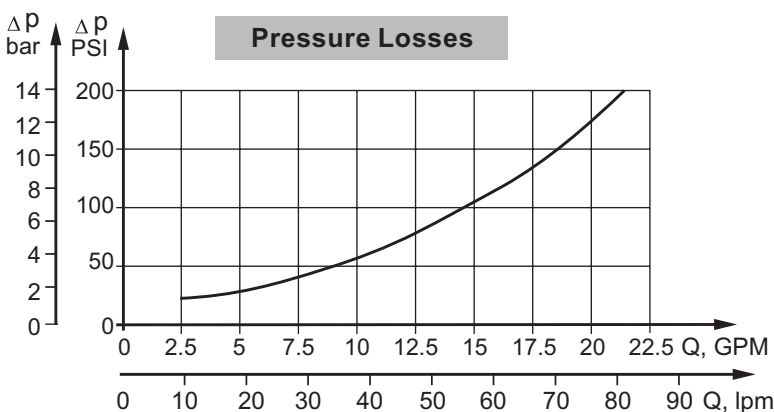
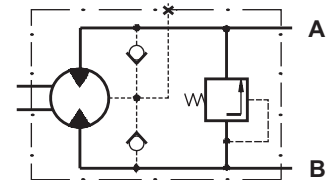

MMD Series with Integrated Internal Crossover Relief Valves
A ↔ B, Δp=100 or 50 bar [1450 or 725 PSI]

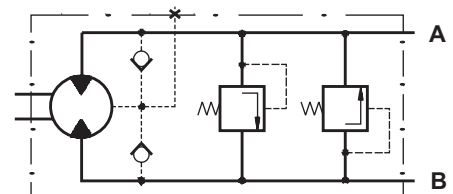

SPECIFICATION DATA

Type		MM 8	MM 12.5	MM 20	MM 32	MM 40	MM 50
Displacement, cm³/rev. [in³/rev.]		8,2 [5]	12,9 [79]	20 [1.22]	31,8 [1.93]	40 [2.44]	50 [3.05]
Max. Speed, [RPM]	Cont.	1950	1550	1000	630	500	400
	Int.*	2440	1940	1250	790	625	500
Max. Torque daNm [lb-in]	Cont.	1,2 [106]	1,7 [150]	2,6 [230]	4,2 [375]	4,2 [375]	4,5 [398]
	Int.*	1,5 [133]	2,3 [205]	3,5 [311]	5,7 [506]	5,7 [506]	5,8 [513]
	Peak**	2,1 [187]	3,3 [293]	5,1 [453]	6,4 [568]	6,6 [584]	8 [708]
Max. Output kW [HP]	Cont.	1,8 [2.4]	2,4 [3.3]	2,4 [3.3]	2,4 [3.3]	1,8 [2.5]	1,7 [2.48]
	Int.*	2,6 [3.6]	3,2 [4.3]	3,2 [4.3]	3,2 [4.3]	3,0 [4.0]	2,1 [2.8]
Max. Pressure Drop bar [PSI]	Cont.	105 [1500]	105 [1500]	105 [1500]	105 [1500]	82,5 [1200]	70 [1015]
	Int.*	140 [2030]	140 [2030]	140 [2030]	140 [2030]	110 [1600]	90 [1300]
	Peak**	200 [2900]	200 [2900]	200 [2900]	200 [2900]	140 [2000]	125 [1815]
Max. Oil Flow lpm [GPM]	Cont.	16 [4.2]	20 [5.5]	20 [5.5]	20 [5.5]	20 [5.5]	20 [5.5]
	Int.*	20 [5.5]	25 [6.6]	25 [6.6]	25 [6.6]	25 [6.6]	25 [6.6]
Max. Inlet Pressure bar [PSI]	Cont.	140 [2030]	140 [2030]	140 [2030]	140 [2030]	140 [2030]	140 [2030]
	Int.*	175 [2540]	175 [2540]	175 [2540]	175 [2540]	175 [2540]	175 [2540]
	Peak**	225 [3260]	225 [3260]	225 [3260]	225 [3260]	225 [3260]	225 [3260]
Max. Return Pressure without Drain Line or Max. Pressure in Drain Line, bar [PSI]	Cont. 0-100 RPM	140 [2030]	140 [2030]	140 [2030]	140 [2030]	140 [2030]	140 [2030]
	Cont. 100-400 RPM	105 [1500]	105 [1500]	105 [1500]	105 [1500]	105 [1500]	105 [1500]
	Cont. 400-800 RPM	50 [725]	50 [725]	50 [725]	50 [725]	50 [725]	50 [725]
	Cont. >800 RPM	20 [290]	20 [290]	20 [290]	-	-	-
Max. Return Pressure with Drain Line bar [PSI]	Int.* 0-max. RPM	140 [2030]	140 [2030]	140 [2030]	140 [2030]	140 [2030]	140 [2030]
	Cont.	140 [2030]	140 [2030]	140 [2030]	140 [2030]	140 [2030]	140 [2030]
	Int.*	175 [2540]	175 [2540]	175 [2540]	175 [2540]	175 [2540]	175 [2540]
Peak**	225 [3260]	225 [3260]	225 [3260]	225 [3260]	225 [3260]	225 [3260]	
Max. Starting Pressure with Unloaded Shaft, bar [PSI]		4 [60]	4 [60]	4 [60]	4 [60]	4 [60]	4 [60]
Min. Starting Torque daNm [lb-in]	At max. press. drop Cont.	0,7 [65]	105 [1,2]	2,1 [190]	3,4 [300]	3,3 [295]	3,7 [330]
	At max. press. drop Int.*	1,0 [90]	150 [1,7]	2,9 [260]	4,8 [425]	4,6 [400]	4,8 [425]
Min. Speed***, [RPM]		50	40	30	30	25	20
Weight, kg [lb] For "F" flange: + .441 [0,200]	MM	1,9 [4.2]	2,0 [4.41]	2,1 [4.63]	2,2 [4.85]	2,3 [5.07]	2,5 [5.51]
	MMF(S)	2,0 [4.41]	2,1 [4.63]	2,2 [4.85]	2,3 [5.07]	2,4 [5.29]	2,6 [5.73]
	MMP	2,2 [4.85]	2,3 [5.07]	2,4 [5.29]	2,5 [5.51]	2,6 [5.73]	2,8 [6.17]
	MMD	2,6 [5.73]	2,7 [5.95]	2,8 [6.17]	2,9 [6.39]	3,0 [6.61]	3,2 [7.05]

* Intermittent operation: the permissible values may occur for max. 10% of every minute.

** Peak load: the permissible values may occur for max. 1% of every minute.

*** For speeds lower than given, consult factory or your regional manager.

- Intermittent speed and intermittent pressure must not occur simultaneously.
- Recommended filtration is per ISO cleanliness code 20/16. A nominal filtration of 25 micron or better.
- Recommend using a premium quality, anti-wear type mineral based hydraulic oil HLP(DIN51524) or HM (ISO 6743/4).
If using synthetic fluids consult the factory for alternative seal materials.
- Recommended minimum oil viscosity 13 mm²/s [70 SUS] at 50°C [122°F].
- Recommended maximum system operating temperature is 82°C [180°F].
- To assure optimum motor life fill with fluid prior to loading and run at moderate load and speed for 10-15 minutes.

FUNCTION DIAGRAMS

MM 8

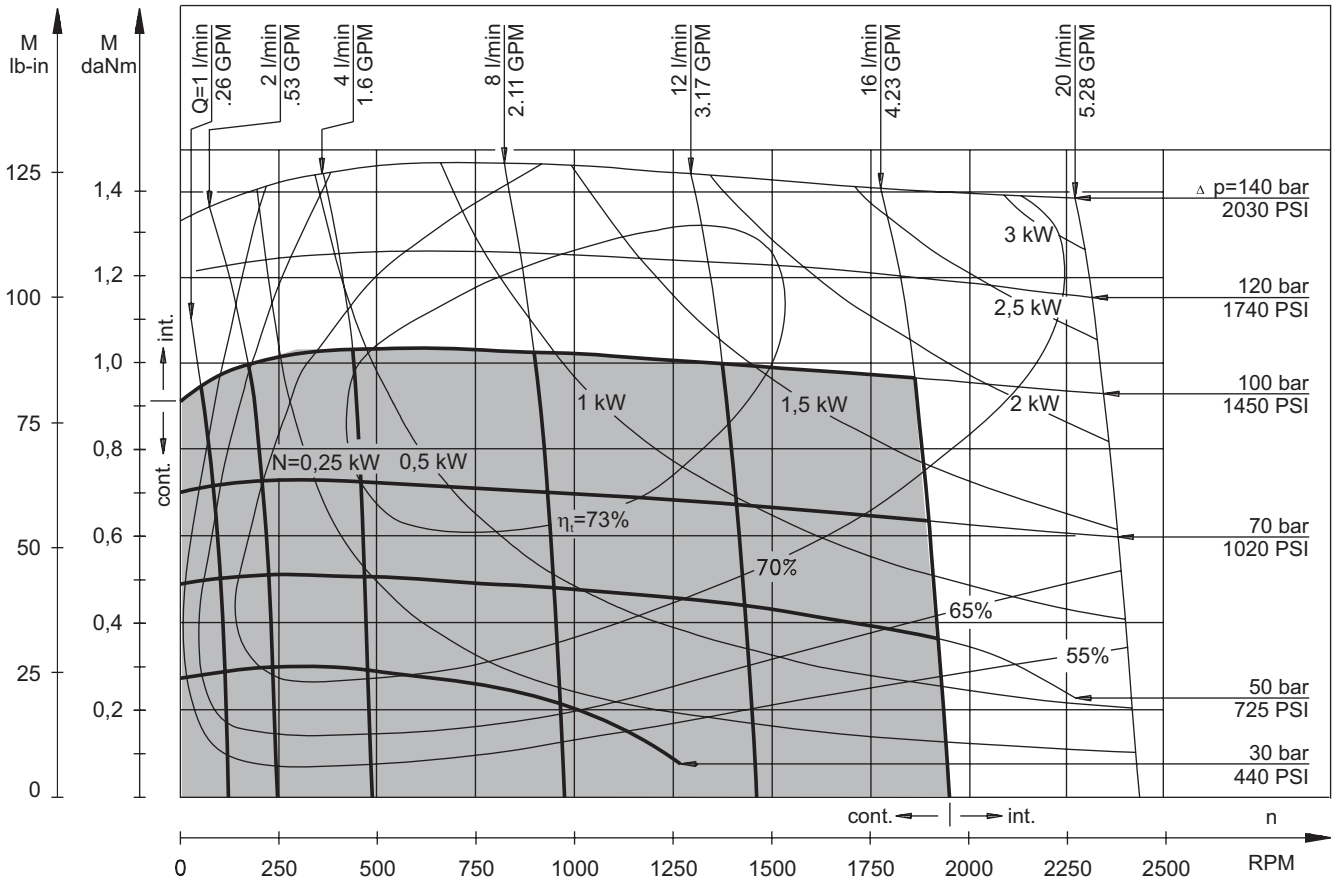

MM 12,5

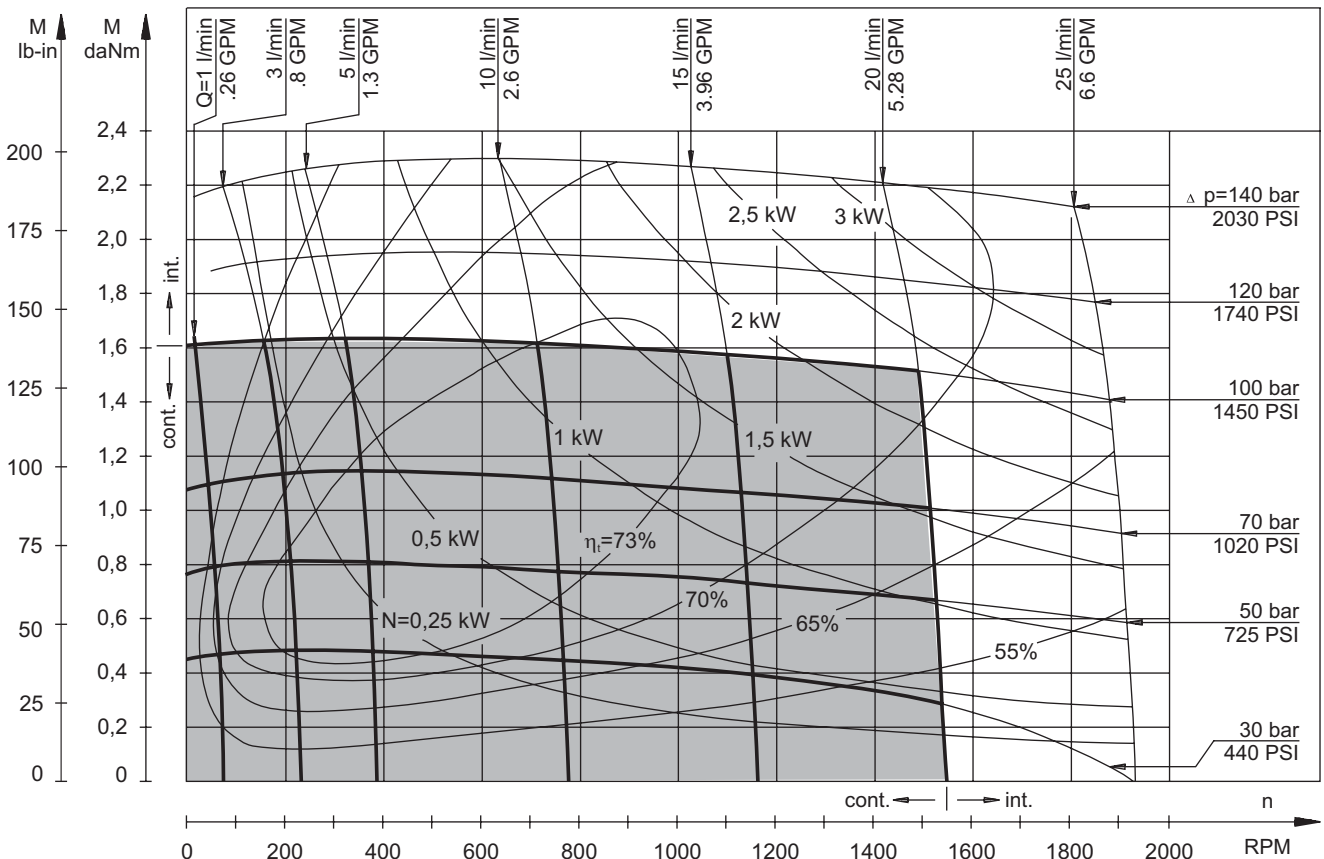

The function diagrams data is for average performance of randomly selected motors at back pressure 5÷10 bar [72.5÷145 PSI] and oil with viscosity of 32 mm²/s [150 SUS] at 50°C [122°F].

FUNCTION DIAGRAMS

MM 20

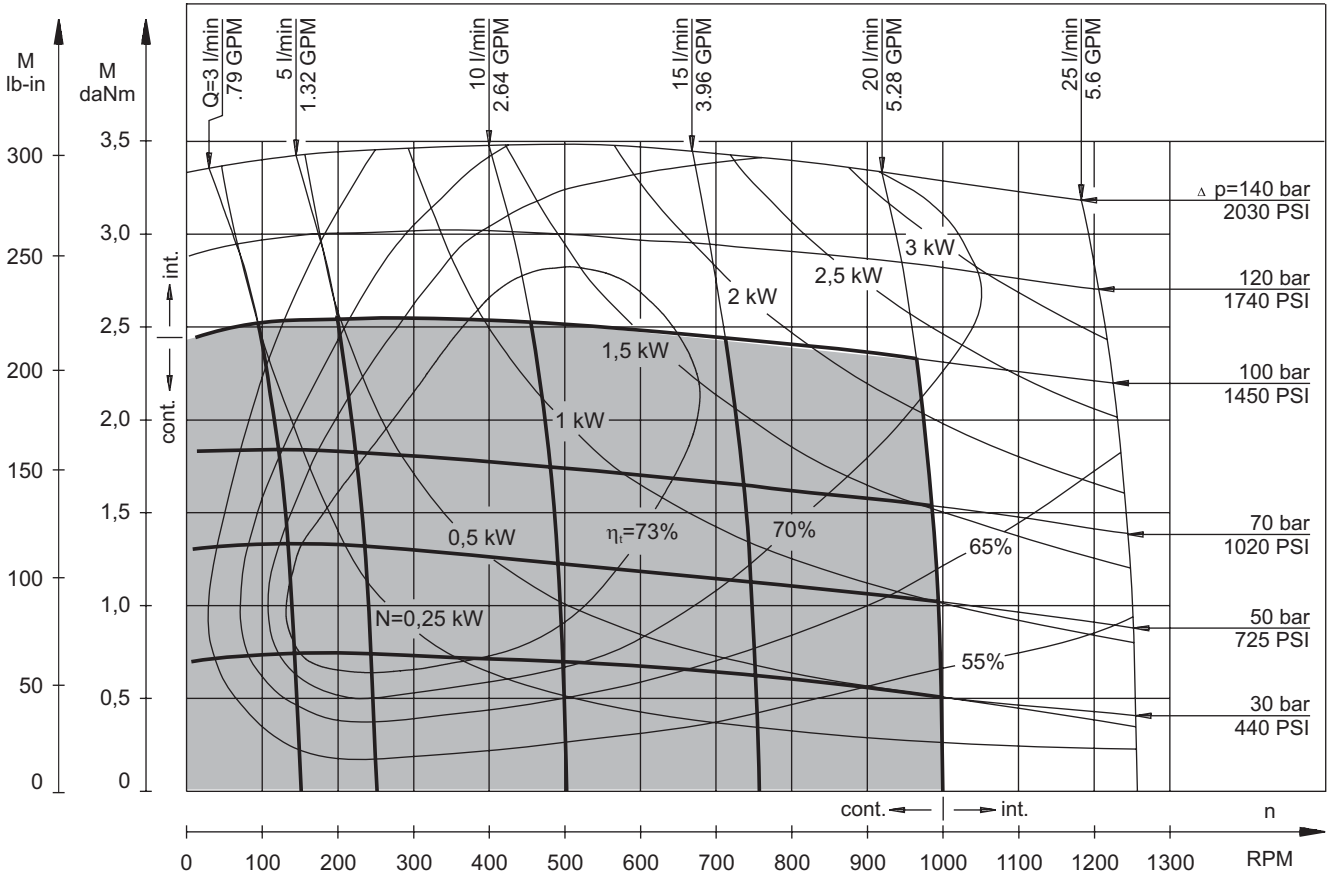

MM 32

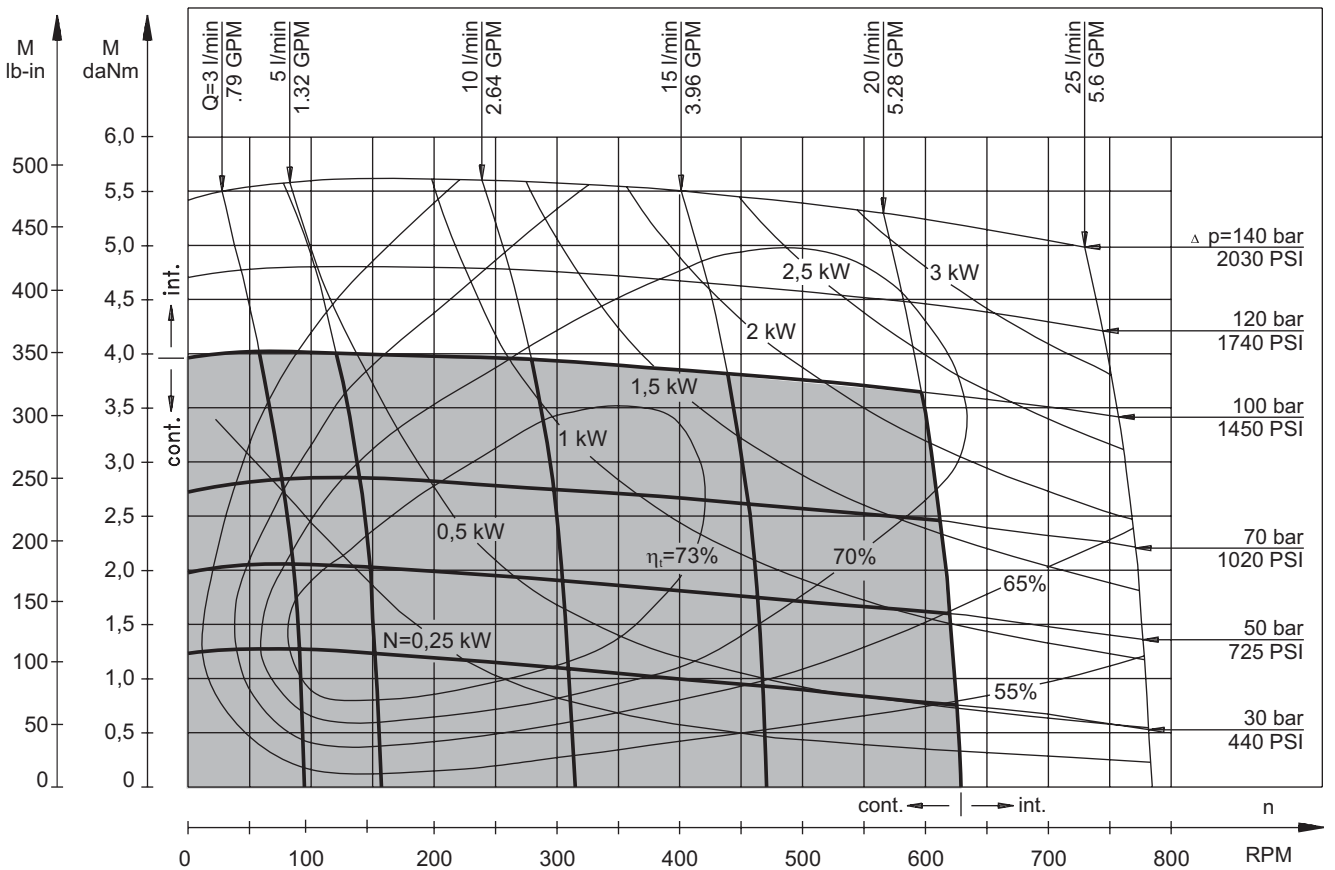

The function diagrams data is for average performance of randomly selected motors at back pressure 5÷10 bar [72.5÷145 PSI] and oil with viscosity of 32 mm²/s [150 SUS] at 50°C [122°F].

FUNCTION DIAGRAMS

MM 40

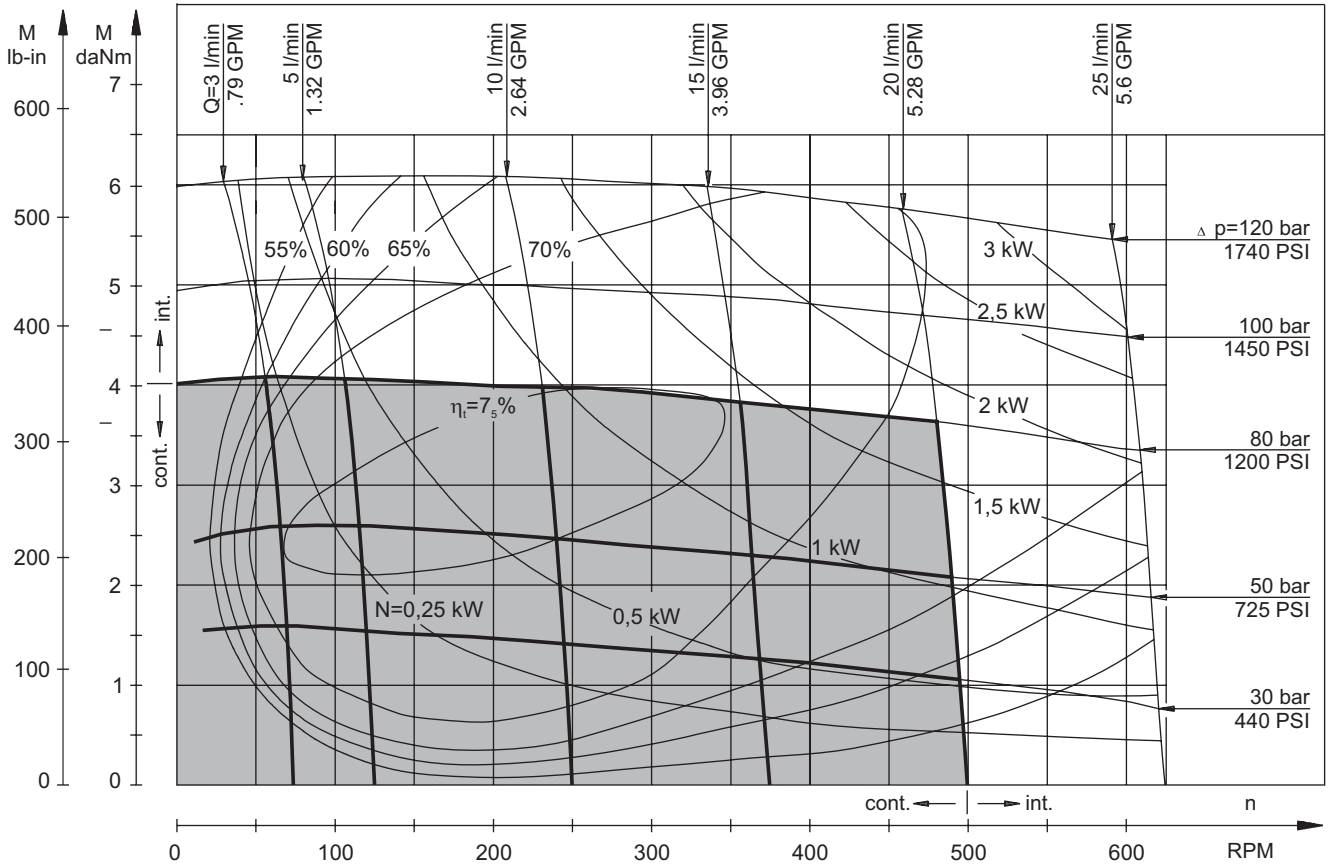

MM 50

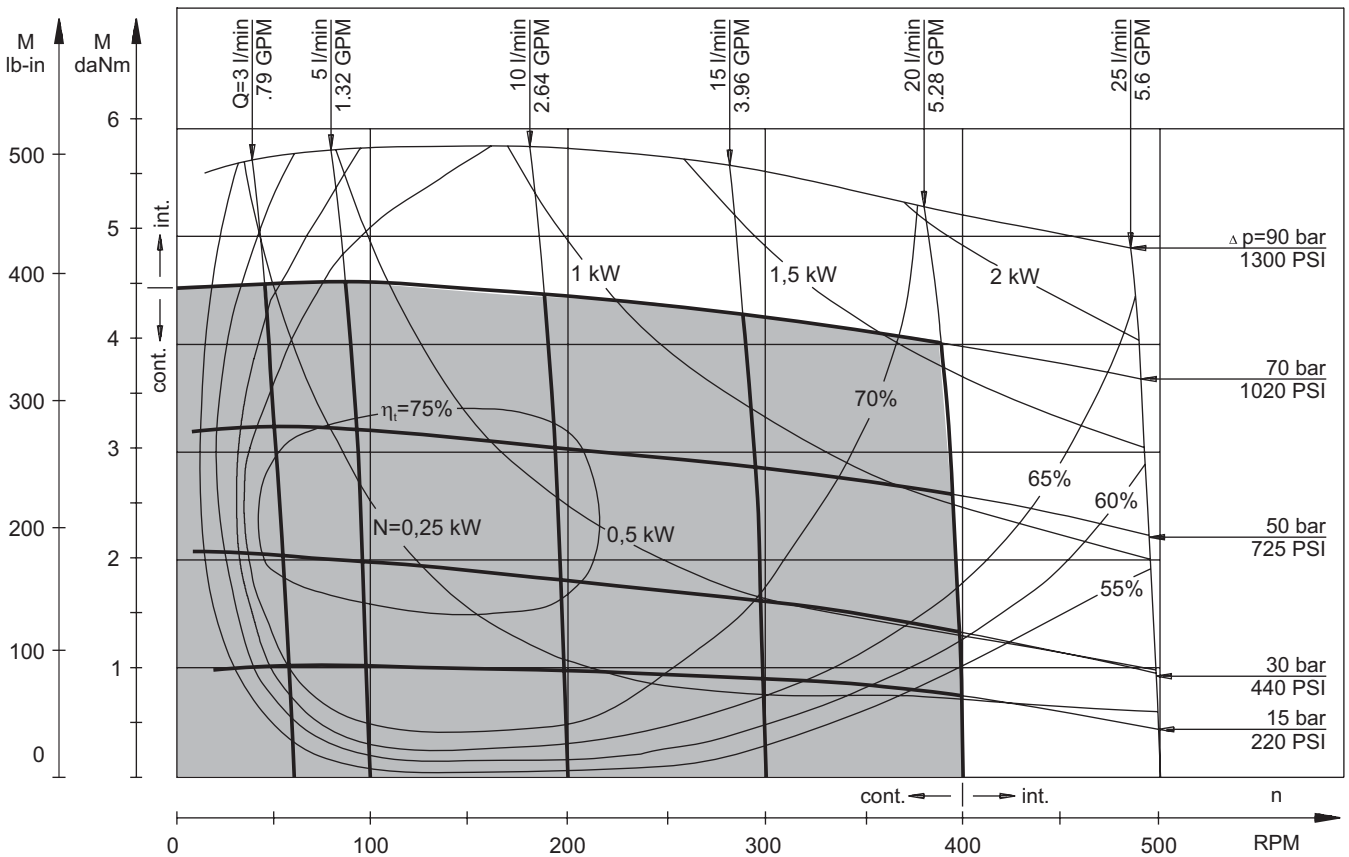

The function diagrams data is for average performance of randomly selected motors at back pressure 5÷10 bar [72.5÷145 PSI] and oil with viscosity of 32 mm²/s [150 SUS] at 50°C [122°F].

DIMENSIONS AND MOUNTING DATA
MM, MMS, MMP, MMD

Three Bolts Mount

SH Shaft C Shaft CK Shaft

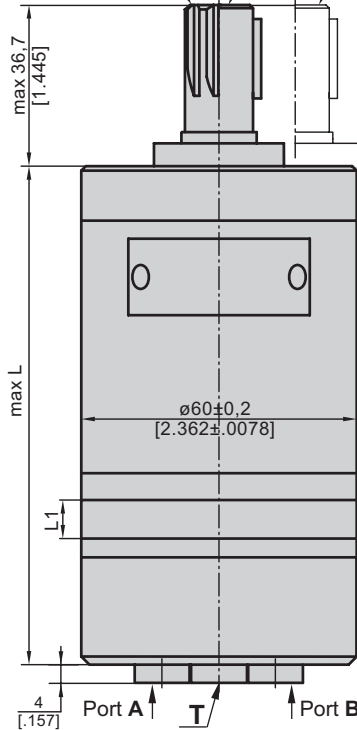

Shaft Dim.
See Page 11

Flange Dim.
See Page 10

Port Dim.
See Page 10

F Oval Mount (2 Holes)

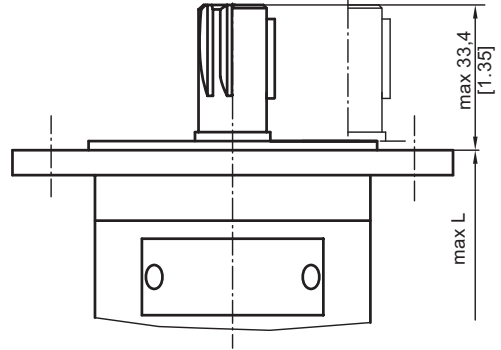

Rear Ports

Standard Rotation

Viewed from Shaft End

Port A Pressurized - **CW**

Port B Pressurized - **CCW**

Reverse Rotation

Viewed from Shaft End

Port A Pressurized - **CCW**

Port B Pressurized - **CW**

S Side Ports

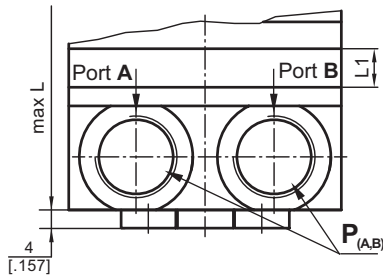

P_(A,B): 2xG3/8 or 2xM18x1,5 - 12 mm [.47 in] depth

T: G1/8 or M10x1 - 10 mm [.39 in] depth

P Side Ports

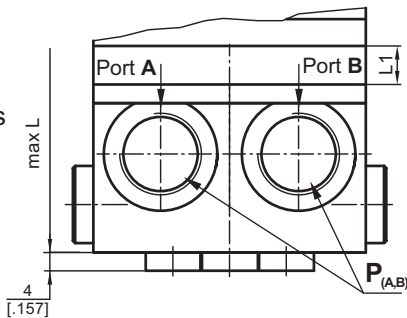

D Side Ports

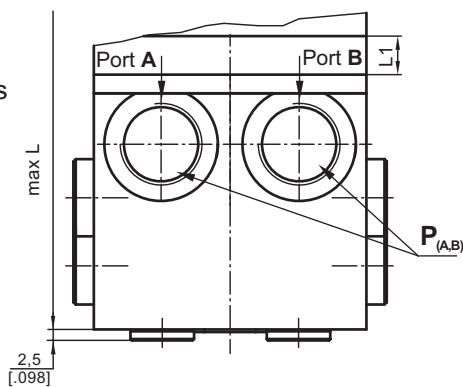

Type	L, mm [in.]	Type	L, mm [in.]	L ₁ , mm [in.]
MM 8	104 [4.094]	MMS 8	105 [4.134]	3,5 [.138]
MM 12,5	106 [4.173]	MMS 12,5	107 [4.213]	5,5 [.217]
MM 20	109 [4.291]	MMS 20	110 [4.331]	8,5 [.335]
MM 32	114 [4.488]	MMS 32	115 [4.528]	13,5 [.531]
MM 40	117,5 [4.626]	MMS 40	118,5 [4.665]	17 [.669]
MM 50	121,5 [4.783]	MMS 50	122,5 [4.823]	21 [.827]

Type	L, mm [in.]	Type	L, mm [in.]	L ₁ , mm [in.]
MMP 8	115 [4.528]	MMD 8	134 [5.276]	3,5 [.138]
MMP 12,5	117 [4.606]	MMD 12,5	136 [5.354]	5,5 [.217]
MMP 20	120 [4.724]	MMD 20	139 [5.472]	8,5 [.335]
MMP 32	125 [4.921]	MMD 32	144 [5.669]	13,5 [.531]
MMP 40	128,5 [5.039]	MMD 40	147,5 [5.807]	17 [.669]
MMP 50	132,5 [5.217]	MMD 50	151,5 [5.965]	21 [.827]

For "F" Flange +3,5 mm



MOUNTING

Three Bolts Mount

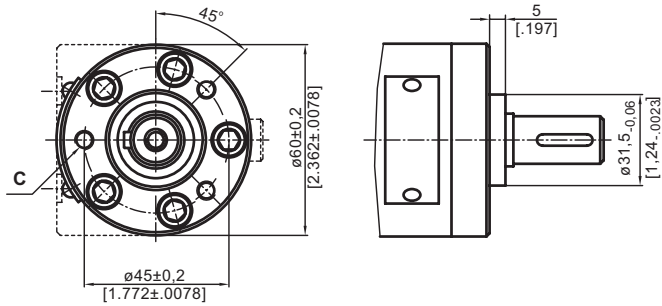

F Oval Mount (2 Holes)

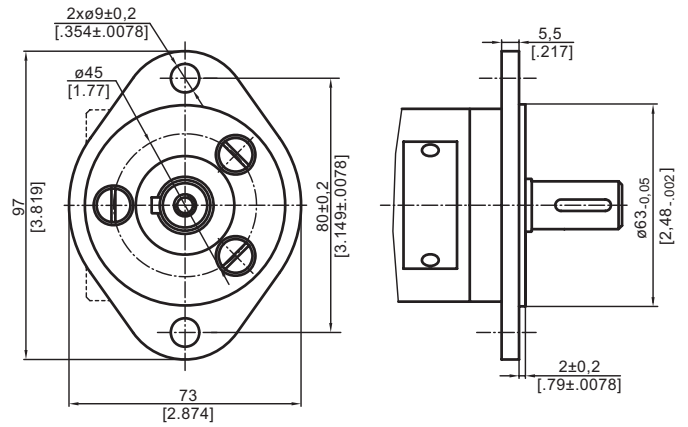

PORTS

Rear Ports

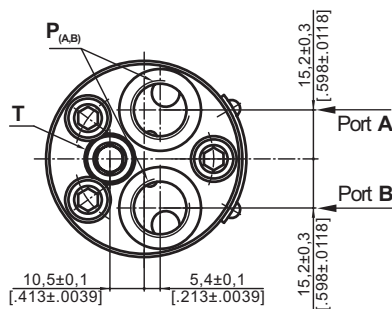

S Side Ports

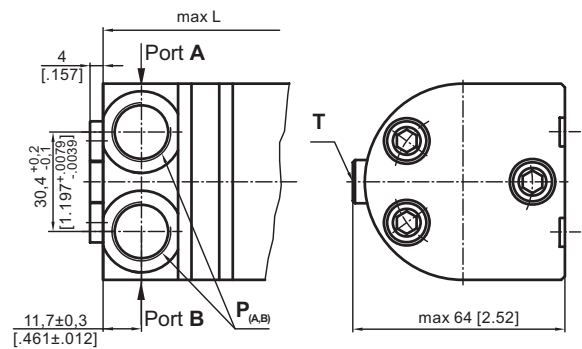

P Side Ports with Single Crossover Relief Valve

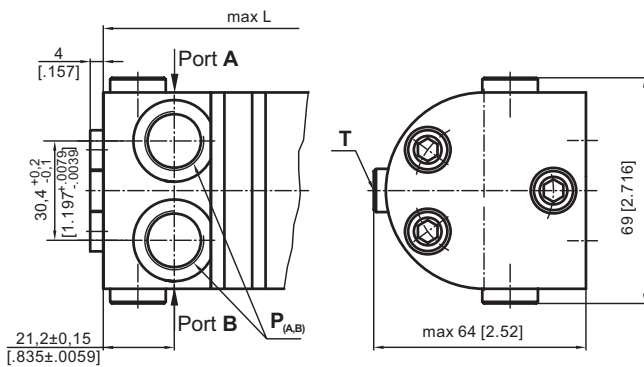

D Side Ports with Dual Crossover Relief Valve

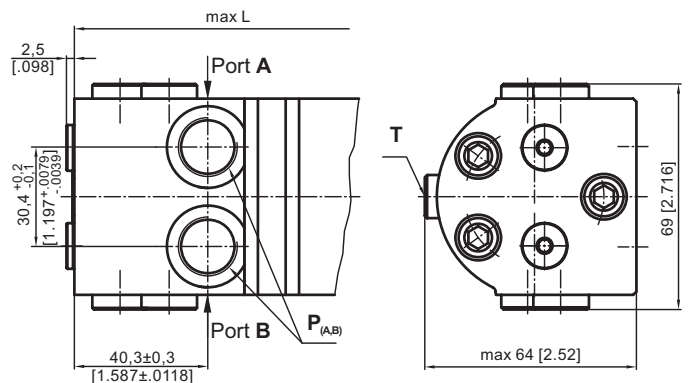

Standard Rotation
Viewed from Shaft End
Port A Pressurized - **CW**
Port B Pressurized - **CCW**

Reverse Rotation
Viewed from Shaft End
Port A Pressurized - **CCW**
Port B Pressurized - **CW**

C : 3xM6 - 12 mm [.47 in] depth
P_(A,B) : 2xG3/8 or 2xM18x1,5 - 12 mm [.47 in] depth
T : G1/8 or M10x1 - 10 mm [.39 in] depth

SHAFT EXTENSIONS

C - $\varnothing 16$ straight, Parallel key 5x5x16 DIN 6885
Max. Torque 3,9 daNm [345 lb-in]

CK - $\varnothing 14$ straight, Parallel key 5x5x16 DIN 6885
Max. Torque 3 daNm [265 lb-in]

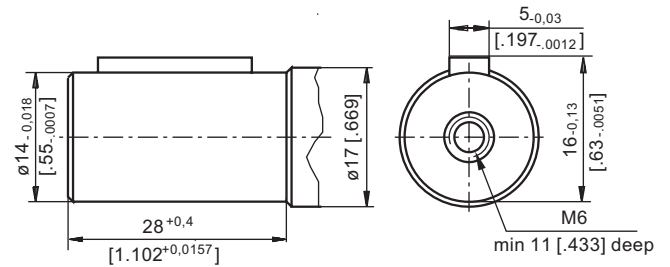
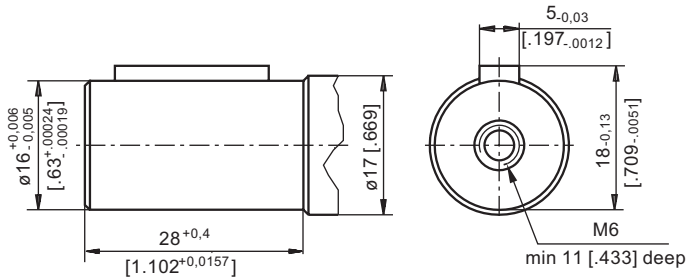

SH - $\varnothing 16,5$ Splined, B17x14 DIN 5482
Max. Torque 4,4 daNm [390 lb-in]

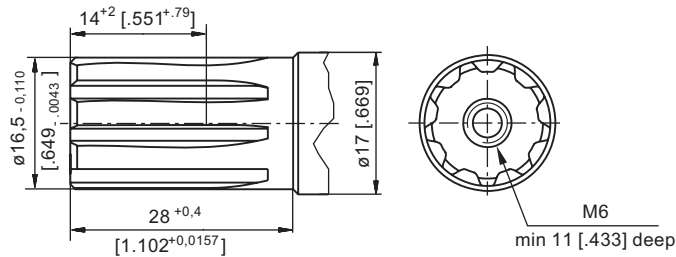

PERMISSIBLE SHAFT LOAD

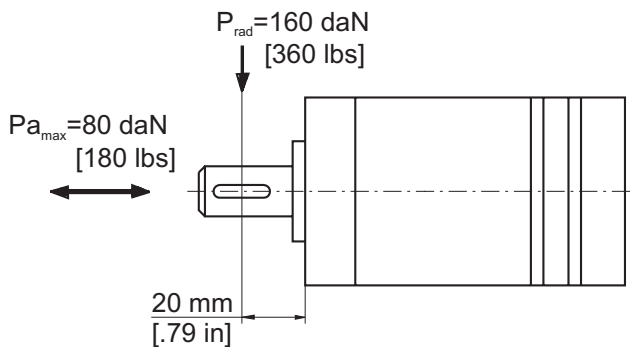

The permissible radial shaft load [Prad] is calculated from the distance [L] between the point of load application and the mounting surface:

$$P_{rad} = \frac{600}{n} \times \frac{13040}{61,5+L}, \text{ [daN]}$$

[L in mm; L ≤ 80 mm]

$$P_{rad} = \frac{600}{n} \times \frac{1155}{2,42 + L}, \text{ [lbs]}$$

[L in inch; L ≤ 3.15 in]

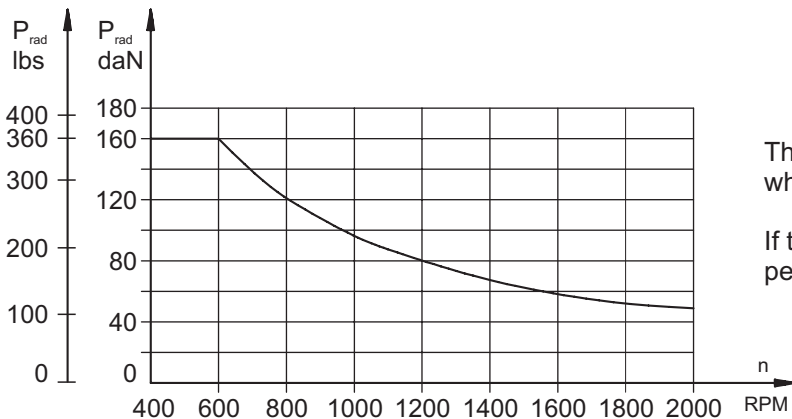

The drawing shows the permissible radial load when L=20 mm [0.79 in].

If the calculated shaft load exceeds the permissible, a flexible coupling must be used.

ORDER CODE

	1	2	3	4	5	6	7	8	9
M M									

Pos.1 - Adjustment Option

- omit - without valve
- P** - Side ports with single crossover relief valve
- D** - Side ports with dual crossover relief valve

Pos.2 - Mounting Flange

- omit - Three bolts mount
- F** - Oval mount, two holes

Pos.3 - Port type (not valid for P and D version)

- omit - Rear ports
- S** - Side ports

Pos.4 - Displacement code

- 8** - 8,2 cm³/rev [1.5 in³/rev]
- 12.5** - 12,9 cm³/rev [1.79 in³/rev]
- 20** - 20,0 cm³/rev [1.22 in³/rev]
- 32** - 31,8 cm³/rev [1.93 in³/rev]
- 40** - 40,0 cm³/rev [2.44 in³/rev]
- 50** - 50,0 cm³/rev [3.05 in³/rev]

Pos. 5 - Shaft Extensions*

- C** - ø16 straight, Parallel key A5x5x16 DIN6885
- VC** - ø16 straight, Parallel key A5x5x16 DIN6885 with corrosion resistant bushing
- CK** - ø14 straight, Parallel key 5x5x16 DIN6885
- SH** - ø16,5 splined, B17x14 DIN 5482

Pos. 6 - Ports

- omit - BSPP (ISO 228)
- M** - Metric (ISO 262)

Pos. 7 - Line to control ** (see page 4)

- /L** - B→A (left running)
- /R** - A→B (right running)

Pos. 8 - Valve Rated Pressure ***

- /50** - Δp=50 bar
- /100** - Δp=100 bar

Pos. 9 - Special Features (see page 98)

Pos.10 - Design Series

- omit - Factory specified

NOTES:

- * The permissible output torque for shafts must not be exceeded!
- ** For **P** option useful only.
- *** For **P** and **D** option useful only.

⚠ **MMP** and **MMD** are available with new crossover relief valves with improved characteristics. The new valves allow easier pressure setting in more wide range: from 50 [725 PSI] to 140 bar [2030 PSI]. For more information about MMP and MMD - series 2 please contact with us.

The hydraulic motors are manganó - phosphatized as standard.

F - FLANGE (2 Holes)

Order No for Flange:48443 014 00

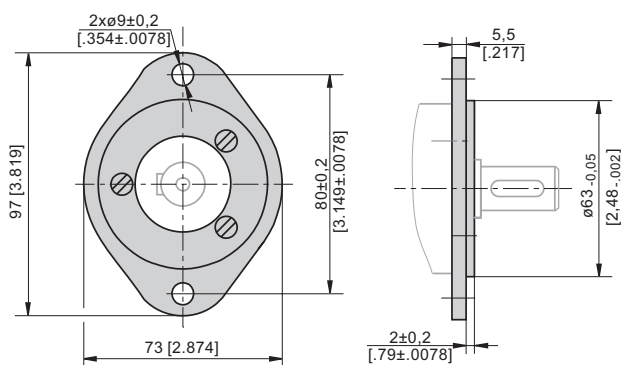

F Flange is mounted to the motor with 3 screws - M6x14. Tightening Torque: 5-6 Nm.