

## BESTELLANGABEN ORDERING CODE

MG 2 550 03 2 1

**PRODUKT SERIE**  
**PRODUCT SERIES**

**TYPEN BEZEICHNUNG**  
**TYPE**

- 510 (MG AIR 2010K)
- 515 (MG AIR 2015K)
- 520 (MG AIR 2020K)
- 524 (MG AIR 2024K)
- 530 (MG AIR 2030K)
- 540 (MG AIR 2040K)
- 550 (MG AIR 2050K)

**VENTILATOR MOTOR TYPR**  
**FAN MOTOR TYP**

- 01 AC 230V 50Hz
- 03 AC 230V-400V 50Hz
- 04 AC 230V-400V 50-60Hz (B14)
- 12 DC 12V
- 24 DC24V
- 56 Vorber. f. Hydraulikmotor Gr.2, Prep. for hydr. mot. gr. 2

**THERMOSTATE**  
**THERMOSTATS**

- 1 Festes Thermostat fixed thermostat 40-28°C
- 2 Festes Thermostat fixed thermostat 50-38°C
- 3 Festes Thermostat fixed thermostat 60-48°C
- 4 Festes Thermostat fixed thermostat 70-58°C
- 5 Festes Thermostat fixed thermostat 80-68°C
- 6 Festes Thermostat fixed thermostat 90-78°C
- 8 Regelbares Thermostat Adjustable thermostat 0-90°C (Tc2)
- 9 Angeschlossenes regelbares Thermostat connected adjustable thermostat 0-90°C (Tr2)

**VENTILATOR TYP**  
**VENTILATING TYPE**

- 01 Luft Ansaugung Suction air flow
- 02 Luft Gebläse Blowing air flow

# Serie K MG2050K

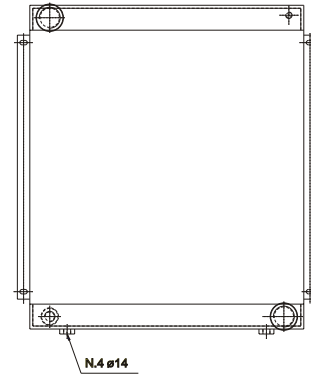
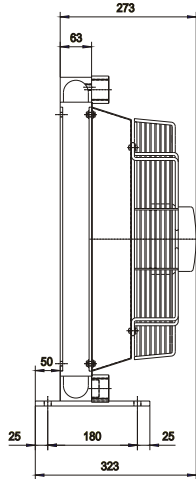
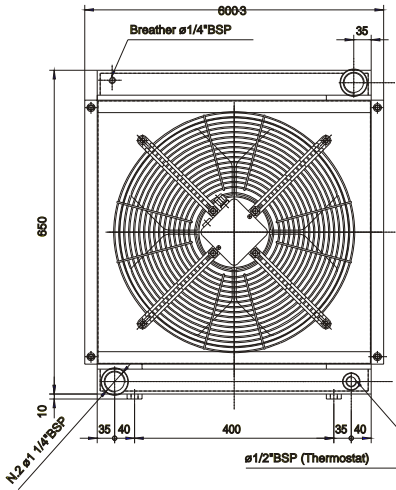

P/N 255003###  
P/N 255001###

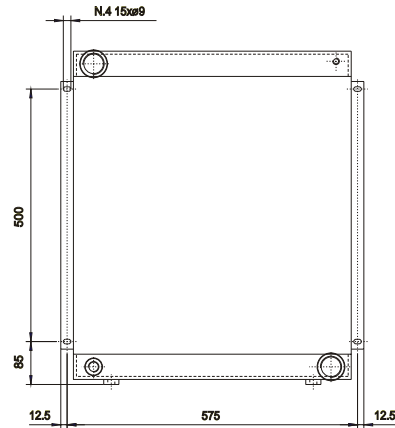
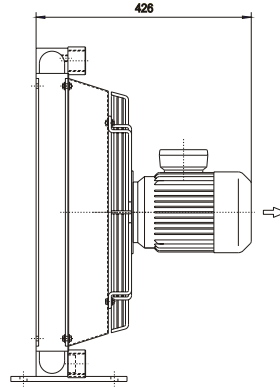
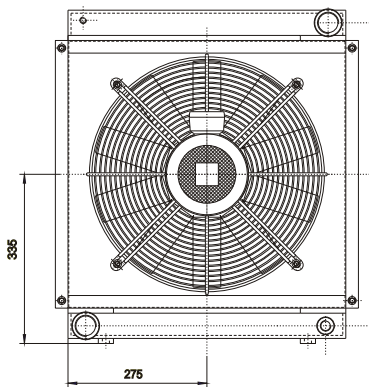

P/N 255004###

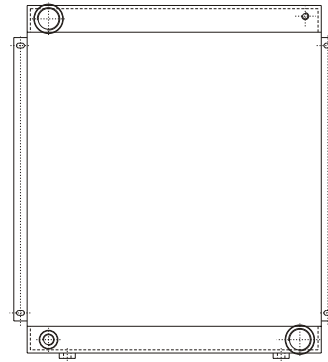
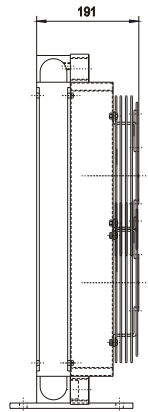
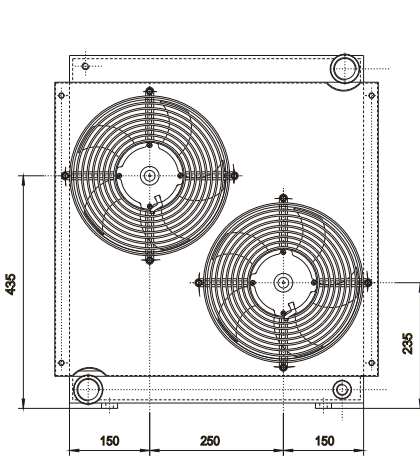

P/N 255012###

P/N 255024###

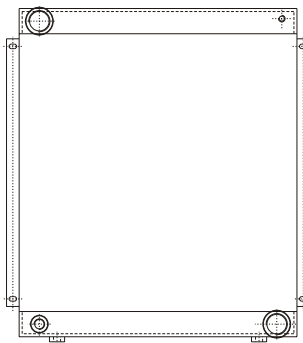
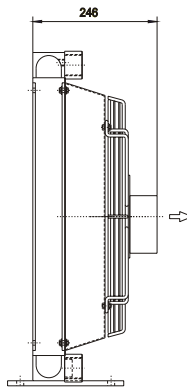
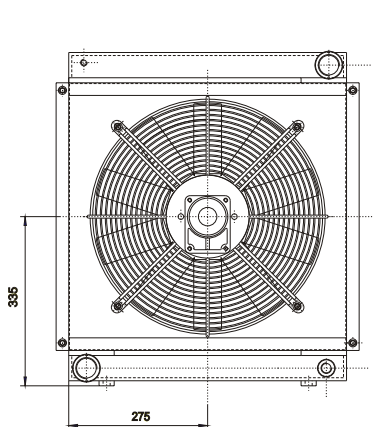

P/N 255056###

Maße und technische Angaben sind nicht bindend.  
Over-all dimensions and technical characteristics are not binding.

P/N	V	Hz	kW	A	rpm	Fan	dB(A)	(m³/h)	IP	lt	kg
255003####	230-400 AC	50/60	0,43	0,9	1340	450	76	5000	54	5	27
255004####	230-400 AC B14	50/60	0,75	1,88	1450	450	79	5200	55	5	30
255012####	12 DC	-	0,15	9,5	3100	280	76	2000	64	5	24
255024####	24 DC	-	0,15	5,6	3100	280	79	2000	64	5	24
255056####	Prepared for Gr. 2 hydraulic Motor					450			-	5	23

Kontakt NHD Contact NHD

## Leistungsdiagramm Performance diagram

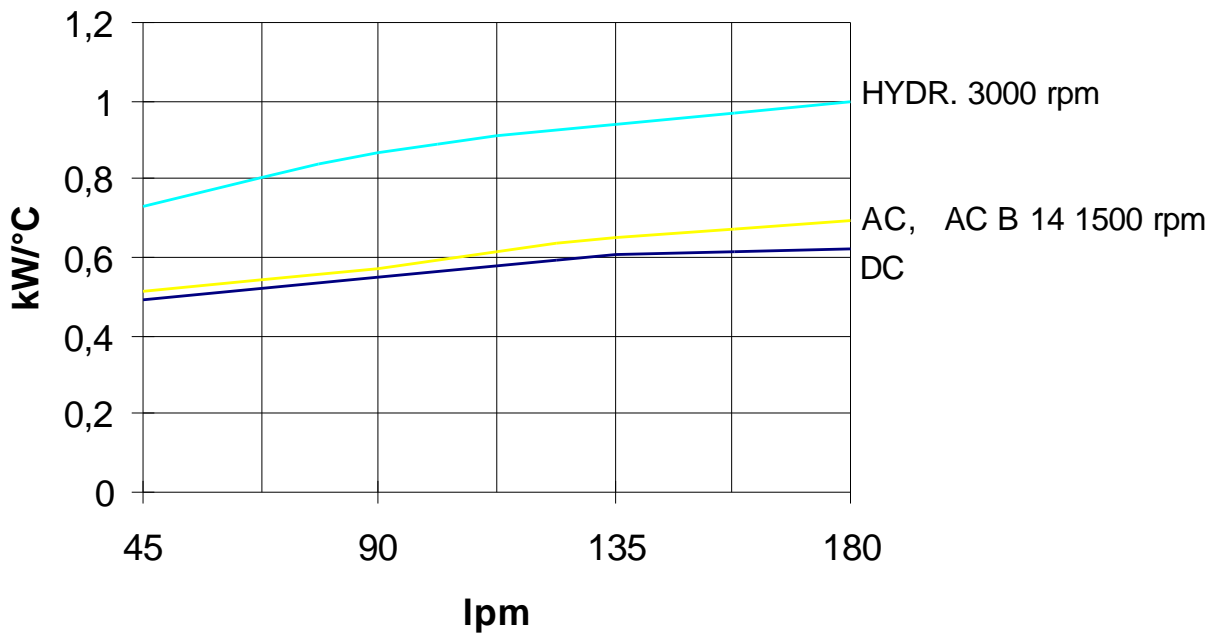

## Druckverlust Pressure drop (ISO VG32)

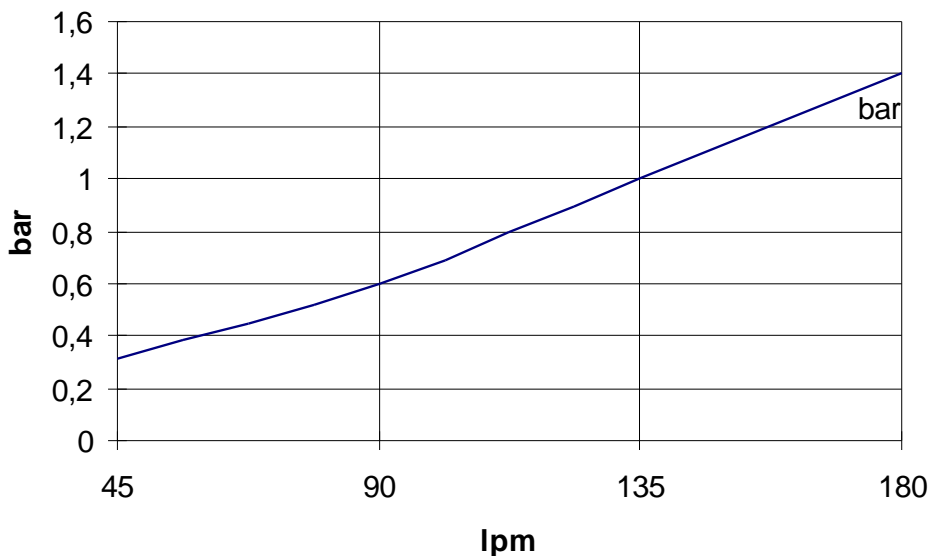

### Korrekturfaktor -F- (Druckverlust) Correction factor -F- (Pressure drop)

cest	10	15	20	30	40	50	60	80	100	200	300
F	0,5	0,65	0,77	1	1,2	1,4	1,6	1,9	2,1	3,3	4,3